

SPECIFICATION

- General Characteristics**
0.5mm FPC XXP SMT 90° Easy On Type
Bottom Contact Tape & Reel 2000 PCS/Reel
- Material&Finish**
Housing:LCP(UL94V-0),Nature
Cover:LCP(UL94V-0),Black
Contact:Phosphor Bronze,Tin Plated Over Nickel
Leg:Phosphor Bronze,Tin Plated Over Nickel
- Electrical Characteristics**
Voltage Rating:50V AC/DC
Current Rating:0.5A AC/DC
- Environmental Characteristics**
Temperature Rating:-25°C~+85°C
- RoHS Compliant**

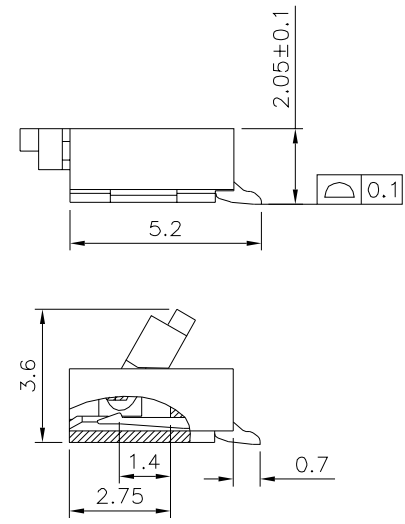
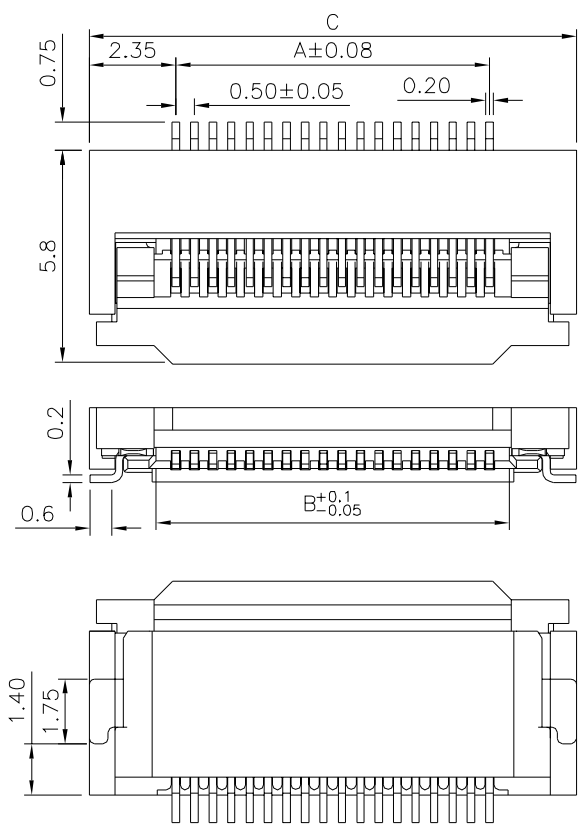
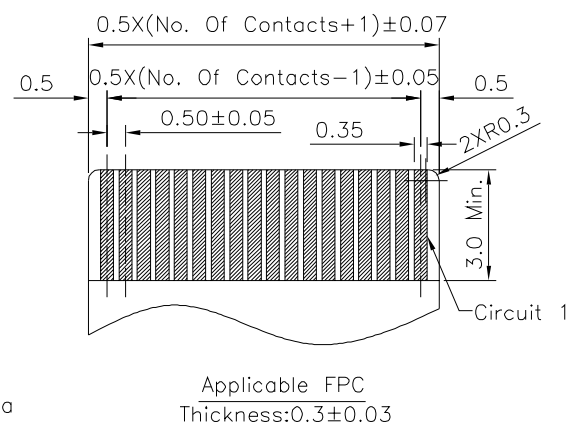
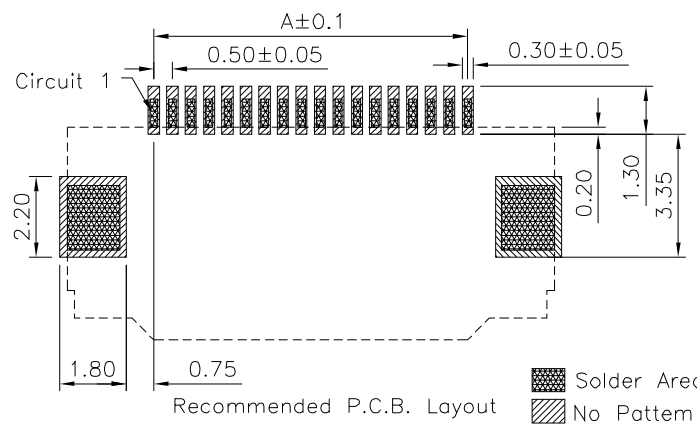

Pin	A	B	C	Pin	A	B	C
4	1.50	2.56	6.2	*34	16.50	17.56	21.2
5	2.00	3.06	6.7	*35	17.00	18.06	21.7
*6	2.50	3.56	7.2	*36	17.50	18.56	22.2
*8	3.50	4.56	7.7	*37	18.00	19.06	22.7
*9	4.00	5.06	8.2	*38	18.50	19.56	23.2
*10	4.50	5.56	8.7	39	19.00	20.06	23.7
*11	5.00	6.06	9.2	*40	19.50	20.56	24.2
*12	5.50	6.56	9.7	*41	20.00	21.06	24.7
*13	6.00	7.06	10.2	*42	20.50	21.56	25.2
*14	6.50	7.56	10.7	43	21.00	22.06	25.7
*15	7.00	8.06	11.2	*44	21.50	22.56	26.2
*16	7.50	8.56	11.7	*45	22.00	23.06	26.7
*17	8.00	9.06	12.2	46	22.50	23.56	27.2
*18	8.50	9.56	12.7	*47	23.00	24.06	27.7
*19	9.00	10.06	13.2	48	23.50	24.56	28.2
*20	9.50	10.56	13.7	*49	24.00	25.06	28.7
*21	10.00	11.06	14.2	*50	24.50	25.56	29.2
*22	10.50	11.56	14.7	*51	25.00	26.06	29.7
*23	11.00	12.06	15.2	52	25.50	26.56	30.2
*24	11.50	12.56	15.7	*53	26.00	27.06	30.7
*25	12.00	13.06	16.2	*54	26.50	27.56	31.2
*26	12.50	13.56	16.7	*55	27.00	28.06	31.7
27	13.00	14.06	17.2	56	27.50	28.56	32.2
*28	13.50	14.56	17.7	*57	28.00	29.06	32.7
29	14.00	15.06	18.2	58	28.50	29.56	33.2
*30	14.50	15.56	18.7	59	29.00	30.06	33.7
31	15.00	16.06	19.2	*60	29.50	30.56	34.2
*32	15.50	16.56	19.7	*61	30.00	31.06	34.7
*33	16.00	17.06	20.2	*64	31.50	32.56	36.2

The Mark Of "*" Are Tooled Already

4UCON 元化興業股份有限公司
4UCON TECHNOLOGY INC.

DRAWING No.		APPROVED BY		UNLESS OTHERWISE SPECIFIED TOLERANCES ARE X. ±0.40 .X ±0.30 XX ±0.20 .XXX ±0.10 ANG. ±2°
21628		MEI		
		CHECKED BY		
		HZF		
		DRAWING BY		
		CYP		
SCALE	NONE	REV.	A0	UNIT mm

△ A0	NEW RELEASE	HZF	12/20/2016
NO. REV.	REVISIONS	CHK	DATE